

DAILY €6

**IVECO**

# Cab Chassis Specifications



## Specifications **50C SINGLE CAB CHASSIS**

### Dimensions (mm)

X	Wheelbase	3450	3750	4100	4350	4750
K	Overall length	5983	6593	6993	7413	8278
	Body length	3525	4135	4535	4955	5820
H	Overall height –unladen	2270	2264	2661	2257	2252
O	Front track	1740	1724	1724	1724	1724
N	Rear track	1542	1542	1542	1542	1542
T	Unladen frame height at end of frame	820	820	820	820	820
	Front ground clearance	182	182	182	182	182
	Rear ground clearance	168	168	168	168	168
Y	Rear overhang	1485	1795	1845	2015	2480
E	Overall width (Cab)	2010	2010	2010	2010	2010
	Turning circle kerb to kerb	12526	13466	14564	15348	16604
	Turning circle wall to wall	13146	14090	15190	15976	17234

### Mass (kg)

GVM		4495	4495	4495	4495
GVM option		5200	5200	5200	5200
GCM		7995	7995	7995	7995
GCM option		8700	8700	8700	8700
Towing capacity with braked trailer		3500	3500	3500	3500
Front axle capacity		2100	2100	2100	2100
Rear axle capacity		3700	3700	3700	3700
Kerb mass front axle		1425	1444	1462	1478
Kerb mass rear axle		695	691	683	690
Kerb mass total*		2120	2135	2145	2168
Payload capacity		2375	2360	2350	2327

\* Kerb masses are with minimal fuel, spare wheel, tools and no driver

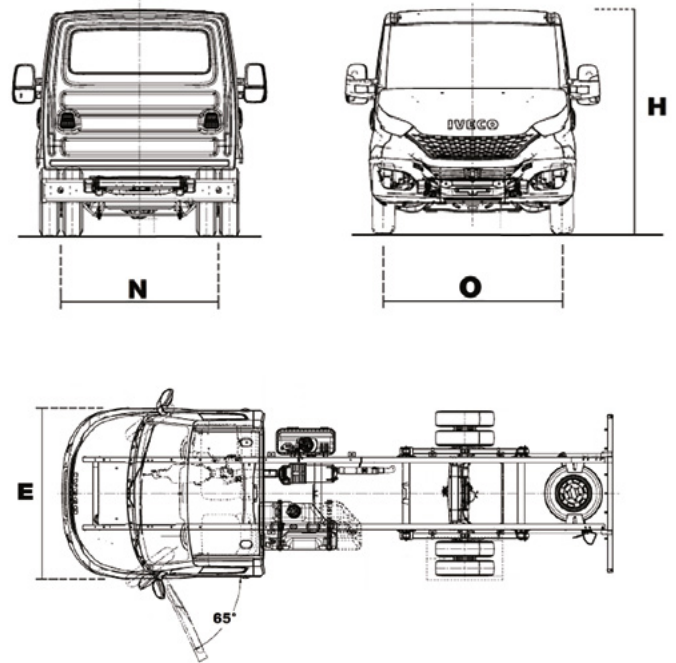

### Front Axle & Suspension

**Capacity:** 2100 kg (50C)

**Suspension Type:** Independent with adjustable steel torsion bar

### Rear Axle & Suspension

**Capacity:** 3700 kg (50C)

**Suspension Type:** Rear parabolic spring

**Optional Suspension:** ECAS - Rear air suspension

**Rear axle ratio:** 50C Single Cab - 3.91: 1

**Optional Differential:** Driver Controlled Differential Lock

### Brakes

**Front / Diameter:** Disc brakes / 290 mm (50C)

**Rear / Diameter:** Disc brakes / 289 mm (50C)

**Parking brake:** Electronic

**Service brakes:** Full ABS disc brakes with floating calipers with auto wear adjustment. Hydraulically operated with vacuum servo assistance. Interdependent dual circuit configuration. Low Brake fluid level indicator - front & rear pad wear sensors. Asbestos free pads.

### Wheels & Tyres

**Wheels:** Steel 5J x R16 (50C);

- Spare wheel included - positioned under chassis
- Dual rear wheels

**Tyre Size:** 195/75 R16 (50C)

### Options:

3450 WB	S
3750 WB	O
4100 WB	O
4350 WB	O
4750 WB	O
F1C 3.0L engine: 210 hp / 470 Nm	O
8-speed Hi-Matic Automatic Transmission	O
ECAS rear air suspension	O
Passenger seat: heated, suspended, adjustable with lumbar support	O
Differential lock	O
Rear step	O
Expansion module	O
Run lock function	O
5.2 tonnes re-rating	O
4.495 tonnes re-rating	S

O – Optional S – Standard

## Specifications **50C DUAL CAB CHASSIS**

### Dimensions (mm)

X	Wheelbase	3450	3750	4100	4350
K	Overall length	5983	6593	6993	7413
	Body length	2775	3385	3785	4205
H	Overall height –unladen	2300	2284	2275	2270
O	Front track	1724	1724	1724	1724
N	Rear track	1542	1542	1542	1542
T	Unladen frame height at end of frame	810	810	810	810
	Front ground clearance	182	182	182	182
	Rear ground clearance	168	168	168	168
Y	Rear overhang	1485	1795	1845	2015
E	Overall width (Cab)	2010	2010	2010	2010
	Turning circle kerb to kerb	12526	13466	14564	15348
	Turning circle wall to wall	13146	14090	15190	15976

### Mass (kg)

GVM		4495	4495	4495	4495
GVM option		5200	5200	5200	5200
GCM		7995	7995	7995	7995
GCM option		8700	8700	8700	8700
Towing capacity with braked trailer		3500	3500	3500	3500
Front axle capacity		2100	2100	2100	2100
Rear axle capacity		3700	3700	3700	3700
Kerb mass front axle		1534	1556	1580	1602
Kerb mass rear axle		786	778	763	765
Kerb mass total*		2320	2334	2343	2367
Payload capacity		2175	2161	2152	2128

\* Kerb masses are with minimal fuel, spare wheel, tools and no driver

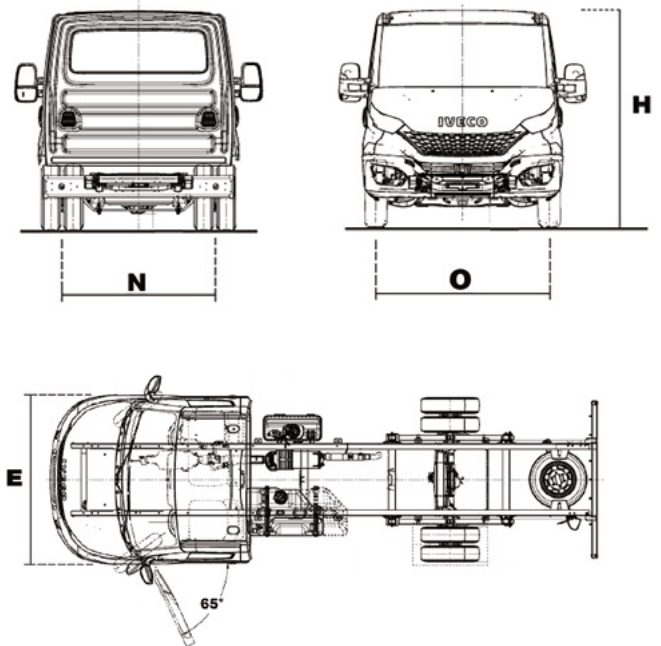

### Front Axle & Suspension

**Capacity:** 2100 kg (50C)

**Suspension Type:** Independent with adjustable steel torsion bar

### Rear Axle & Suspension

**Capacity:** 3700 kg (50C)

**Suspension Type:** Rear parabolic spring

**Optional Suspension:** ECAS - Rear air suspension

**Rear axle ratio:** 50C Dual Cab - 4.44: 1

**Optional Differential:** Driver Controlled Differential Lock

### Brakes

**Front / Diameter:** Disc brakes / 290 mm (50C)

**Rear / Diameter:** Disc brakes / 289 mm (50C)

**Parking brake:** Electronic

**Service brakes:** Full ABS disc brakes with floating calipers with auto wear adjustment. Hydraulically operated with vacuum servo assistance. Interdependent dual circuit configuration. Low Brake fluid level indicator - front & rear pad wear sensors. Asbestos free pads.

### Wheels & Tyres

**Wheels:** Steel 5J x R16 (50C)

- Spare wheel included - positioned under chassis
- Dual rear wheels

**Tyre Size:** 195/75 R16 (50C)

### Options:

3450 WB	S
3750 WB	O
4100 WB	O
4350 WB	O
F1C 3.0L engine: 210 hp / 470 Nm	O
8-speed Hi-Matic Automatic Transmission	O
3.92 Rear axle ratio	O
3.6 Rear axle ratio	O
ECAS rear air suspension	O
Passenger seat: heated, suspended, adjustable with lumbar support	S
Differential lock	O
Rear step	O
Expansion module	O
Run lock function	O
5.2 tonnes re-rating	O
4.495 tonnes re-rating	S

O – Optional S – Standard



## Specifications 70C SINGLE CAB CHASSIS

### Dimensions (mm)

X Wheelbase	3750	4100	4350	4750
K Overall length	6593	6993	7413	8278
Body length	4135	4535	4955	5820
H Overall height -unladen	2320	2312	2305	2299
O Front track	1725	1725	1725	1725
N Rear track	1660	1660	1660	1660
T Unladen frame height at end of frame	930	930	930	930
Front ground clearance	165	165	165	165
Rear ground clearance	169	169	169	169
Y Rear overhang	1795	1845	2015	2480
E Overall width (Cab)	2052	2052	2052	2052
Turning circle kerb to kerb	13048	14108	14866	16078
Turning circle wall to wall	13694	14758	15518	16734

### Mass (kg)

GVM	7200	7200	7200	7200
GVM option	4495	4495	4495	4495
GCM	10700*	10700*	10700*	10700*
GCM option	7995	7995	7995	7995
Towing capacity with braked trailer	3500	3500	3500	3500
Front axle capacity	2500	2500	2500	2500
Rear axle capacity	5350	5350	5350	5350
Kerb mass front axle	1522	1544	1562	1563
Kerb mass rear axle	923	914	927	765
Kerb mass total*	2320	2334	2343	2367
Payload capacity	2175	2161	2152	2128

\* 10500kg limit if optioned with Hi-Matic transmission

\*\* Kerb masses are with minimal fuel, spare wheel, tools and no driver

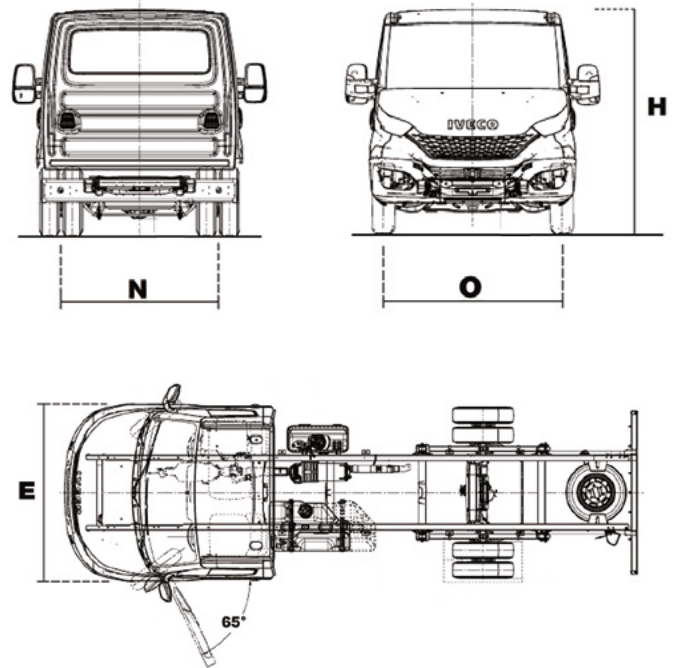

### Front Axle & Suspension

**Capacity:** 2500 kg (70C)

**Suspension Type:** Independent with adjustable steel torsion bar

### Rear Axle & Suspension

**Capacity:** 5350 kg (70C)

**Suspension Type:** Rear parabolic spring

**Optional Suspension:** ECAS - Rear air suspension

**Rear axle ratio:** 70C Single Cab - 4.30: 1

**Optional Differential:** Driver Controlled Differential Lock

### Brakes

**Front / Diameter:** Disc brakes / 301 mm (70C)

**Rear / Diameter:** Disc brakes / 306 mm (70C)

**Parking brake:** Electronic

**Service brakes:** Full ABS disc brakes with floating calipers with auto wear adjustment. Hydraulically operated with vacuum servo assistance. Interdependent dual circuit configuration. Low Brake fluid level indicator - front & rear pad wear sensors. Asbestos free pads.

### Wheels & Tyres

**Wheels:** Steel 6J x R16 (70C)

- Spare wheel included - positioned under chassis
- Dual rear wheels

**Tyre Size:** 225/75 R16 (70C)

### Options:

3750 WB	S
4100 WB	O
4350 WB	O
4750 WB	O
FIC 3.0L engine: 210 hp / 470 Nm	O
8-speed Hi-Matic Automatic Transmission	O
3.92 Rear axle ratio	O
3.6 Rear axle ratio	O
ECAS rear air suspension	O
Passenger seat: heated, suspended, adjustable with lumbar support	S
Differential lock	O
Rear step	O
Expansion module	O
Run lock function	O
4.495 tonnes re-rating	O

O - Optional S - Standard

## Specifications 70C DUAL CAB CHASSIS

### Dimensions (mm)

X	Wheelbase	3750	4100	4350	4750
K	Overall length	6593	6993	7413	8278
	Body length	3385	3785	4205	4995
H	Overall height -unladen	2335	2321	2314	2302
O	Front track	1725	1725	1725	1725
N	Rear track	1660	1660	1660	1660
T	Unladen frame height at end of frame	900	900	900	900
	Front ground clearance	179	179	179	179
	Rear ground clearance	150	150	150	150
Y	Rear overhang	1795	1845	2015	2480
E	Overall width (Cab)	2052	2052	2052	2052
	Turning circle kerb to kerb	13048	14108	14866	16078
	Turning circle wall to wall	13694	14758	15518	16734

### Mass (kg)

GVM		7000	7000	7000	7000
GVM option		4495	4495	4495	4495
GCM		10500	10500	10500	10500
GCM option		7995	7995	7995	7995
Towing capacity with braked trailer		3500	3500	3500	3500
Front axle capacity		2500	2500	2500	2500
Rear axle capacity		5350	5350	5350	5350
Kerb mass front axle		1638	1666	1688	1702
Kerb mass rear axle		1008	992	1000	1011
Kerb mass total*		2646	2658	2688	2713
Payload capacity		4354	4342	4312	4287

\* Kerb masses are with minimal fuel, spare wheel, tools and no driver

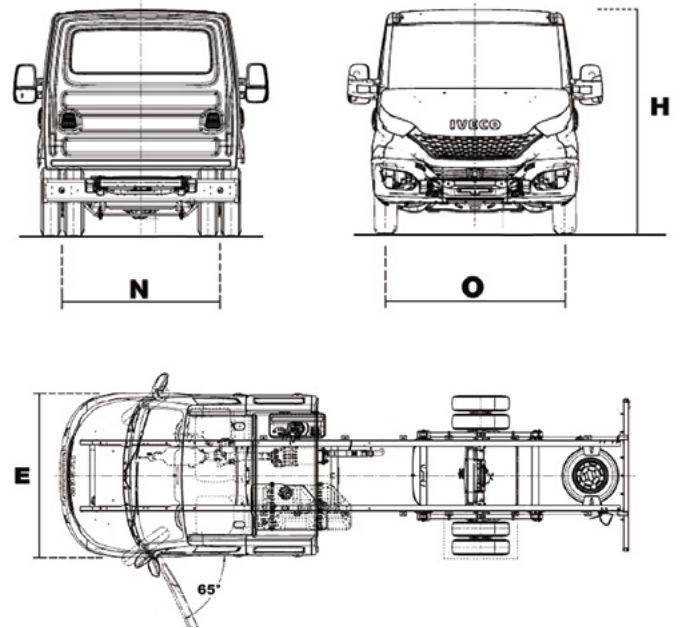

### Front Axle & Suspension

**Capacity:** 2500 kg (70C)

**Suspension Type:** Independent with adjustable steel torsion bar

### Rear Axle & Suspension

**Capacity:** 5350 kg (70C)

**Suspension Type:** Rear parabolic spring

**Optional Suspension:** ECAS - Rear air suspension

**Rear axle ratio:** 70C Dual Cab - 4.556:1

**Optional Differential:** Driver Controlled Differential Lock

### Brakes

**Front / Diameter:** Disc brakes / 301 mm (70C)

**Rear / Diameter:** Disc brakes / 306 mm (70C)

**Parking brake:** Electronic

**Service brakes:** Full ABS disc brakes with floating calipers with auto wear adjustment. Hydraulically operated with vacuum servo assistance. Interdependent dual circuit configuration. Low Brake fluid level indicator - front & rear pad wear sensors. Asbestos free pads.

### Wheels & Tyres

**Wheels:** Steel 6J x R16 (70C)

- Spare wheel included - positioned under chassis
- Dual rear wheels

**Tyre Size:** 225/75 R16 (70C)

### Options:

3750 WB	S
4100 WB	O
4350 WB	O
4750 WB	O
FIC 3.0L engine: 210 hp / 470 Nm	O
8-speed Hi-Matic Automatic Transmission	O
4.3 Rear axle ratio	O
ECAS rear air suspension	O
Passenger seat: heated, suspended, adjustable with lumbar support	S
Differential lock	O
Rear step	O
Expansion module	O
Run lock function	O
4,495 tonnes re-rating	O

O - Optional S - Standard

## Optional **UPGRADE PACKS**

### Hi-Business Pack

- Hi-Connect multimedia system with GPS navigation
- Open storage with inductive plus USB charge
- Fog lights
- Full L.E.D Headlights



Fog Lights



Inductive Charge

### Hi-Comfort Pack

- Automatic controlled air conditioning
- Leather covered steering wheel
- Tyre Pressure Monitoring System (TPMS)
- Automatic wipers and headlights control

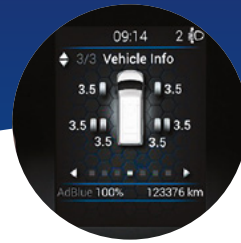

TPMS Display



Air Conditioning



### Hi-Technology Pack – Automatic Transmission

- Queue assist
- Lane departure warning
- City brake
- Traction plus and hill descent
- Automatic high beam control

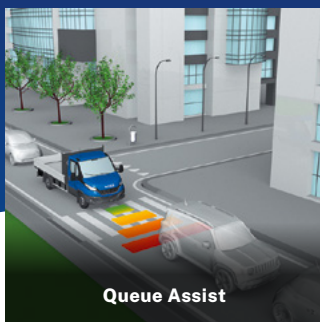

Queue Assist



Lane departure warning

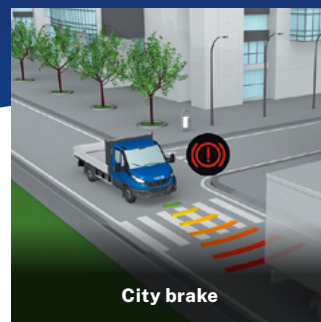

City brake



Traction plus

## Specifications

### Engine

180EVID F1C Euro 6 Heavy Duty engine with variable geometry turbine (VGT)

**Maximum Output:** 132 kW (180 HP) @ 3500 rpm

**Maximum Torque:** 430 Nm (317 ft-lbs) @ 1500 rpm

**Emissions Technology:** Exhaust Gas Recirculation and Selective Catalytic Reduction

**Total Displacement:** F1C: 3.0 litre

**Exhaust:** Muffler horizontally positioned on the right side and tailpipe located mid-way down right side of vehicle

**Optional Engine:** 210EVID - Engine F1C 210 Hp EURO 6 Heavy Duty with Electronically-controlled variable geometry turbine (e-VGT).

**Maximum Output:** 155 kW (210 HP) @ 3500

**Maximum Torque:** 470 Nm (347 ft-lbs) @ 1500

### Transmission

Standard 6-speed Synchronesh Manual Transmission (manual not available with 210 hp engine option)

**Type:** 2840.6 OD 1st 5.375, 2nd 3.154, 3rd 2.041, 4th 1.365, 5th 1.000, 6th 0.791 OD, Rev.4.838

**Optional Transmission (for 180 hp engine; standard for 210 hp engine):** 8-speed ZF Torque Converter Automatic (Hi-Matic 8HP70L)

**Type:** 8HP70L. 1st 4.696, 2nd 3.130, 3rd 2.104, 4th 1.667, 5th 1.285, 6th 1, 7th 0.839 - O.D. 8th 0.667 - D.O.D, rev. 3.297

### Steering

**Type:** Hydraulic power steering

**Diameter:** 380 mm diameter steering wheel with telescopic adjustment

### Clutch

**Type:** Single dry plate hydraulic control

**Diameter:** 280 mm (180 hp)

### Chassis

**Type:** C Section steel longitudinal side members and tubular cross members

### Electrical System

**Type:** 12V

**Battery:** 12V-110 Ah (Smart-charging)

**Smart Alternator:** 12V-220 A

**Trailer Wiring:** Wiring to rear of chassis

### Safety

- **ESP9** - includes ABS (Antilock Braking System), EBD (Electronic Brake force Distribution), ASR (Anti Slip Regulator), MSR (Motor Drag torque control) Hill Holder (Assisted uphill departure), HBA (Hydraulic Brake Assist), LAC (Load Adaptive Control), TSM (Trailer sway mitigation), RMI (Roll Movement Intervention), ROM (Roll Over Mitigation) & Crosswind assist
- Four SRS airbags
- Advanced Emergency Braking System (AEBS)

### Cabin Features

- Driver, passenger and curtain airbags with seat belt pretensioners
- Suspended, heated and fully adjustable driver seat with armrest
- Suspended, heated and fully adjustable passenger seat with armrest (dual cab)
- Bench seat with two occupant capacity, under seat storage and fold down table (single cab)
- Second row seating for up to four passengers (dual cab models)
- Adaptive cruise control
- Electric windows
- Exterior mirrors with integrated wide angle and direction indicators, heated and electronically adjustable
- Overhead console with storage shelf
- Large dual storage pockets in doors
- Document storage compartment
- Body builder connections
- 2 cup and 2x bottle holders
- Air conditioning
- Electronic parking brake
- Ecoswitch Pro
- 2 spotlights
- 4 loud speakers

### Lights

- Daytime running lights
- Optional full LED headlights

### Dashboard

- 3.5" TFT display and silver dial rings
- TFT Display Panel includes: digital speedometer, ADAS (Advanced Driver-Assistance Systems) dashboard, ADAS quick menu, TPMS, oil, battery and service information. Navigation and phone multimedia, fuel economy, trip computer, vehicle settings, display settings and diagnostics.
- Engine oil level display
- Hi-Connect Multimedia System
- Instrument light dimmer switch
- Dash-mounted gear lever
- 3 storage areas on top of dash
- MP3 player, USB and AUX connectivity, Bluetooth with steering wheel controls

### Security

- Central locking with remote control
- Steering lock
- Engine immobiliser
- Run Lock Function (Only available if Expansion Module option is selected)

### Fuel System

- 100 litres with fuel cap location on passenger side
- 20 litre Adblue



IVECO Trucks Australia Limited ABN 86 004 065 061 Princes Highway, Dandenong, Victoria 3175 PO Box 117 Dandenong, Victoria 3175 Telephone (03) 9238 2200 [www.iveco.com.au](http://www.iveco.com.au) The information in this document was correct at the time of printing. The data in this document is approximate. If an exact weight or dimension is required please contact your local authorised IVECO Dealer. Always consult an authorised IVECO Dealer for the latest information on the vehicle before deciding to place an order. Overseas images are shown throughout this document and images may refer to equipment that is optional. The models described can be subject to modifications without any notice by the manufacturer. IVE3053CCSS, 05/2022.